

## Finishing Process

# MRC-300 Grinding Machine with Auto Regulation



It rectifies the body of cork stoppers for the required diameter (regulation of the ovality of the surface). The setup activities are automatic by the appliance of servomotors.



### Source

Power Supply  
415/240V (3Ph+N+T) 50 Hz



### Power

Installed Power 10.0 kW



### Compressed Air

Compressed Air Supply  
5 to 7 bar



### Noise

< 70 dB



### Cadence

Nominal cadence  
15 000 to 20 000 corks/hour  
(24x38 mm)

## General Features

- ✓ Machine with PLC (operation with industrial computer);
- ✓ Machine with servomotors for setups;
- ✓ Possibility of rectifying corks of different dimensions;
- ✓ Semi-automatic system for stones cleaning;
- ✓ Monitoring of the effort made in the grinding operation;
- ✓ Fully controlled by HMI.

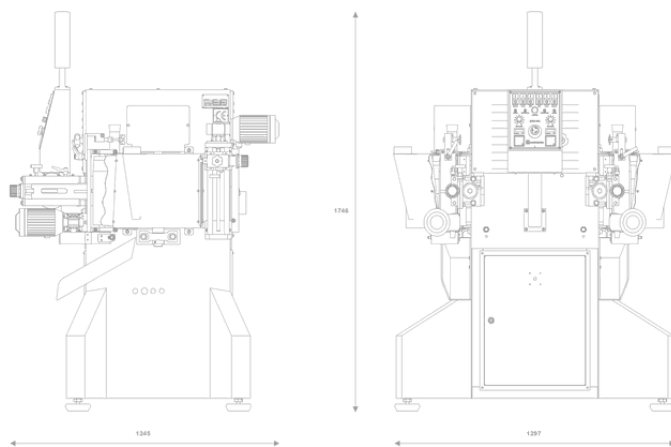

### Dimensions

H 1746 mm x D 1245 mm x W 1297 mm



[www.azevedosindustria.com](http://www.azevedosindustria.com)  
Lourosa, Portugal

+351 22 747 15 70 (Call cost for national fixed network) ▪ [geral@azevedosindustria.com](mailto:geral@azevedosindustria.com)

